

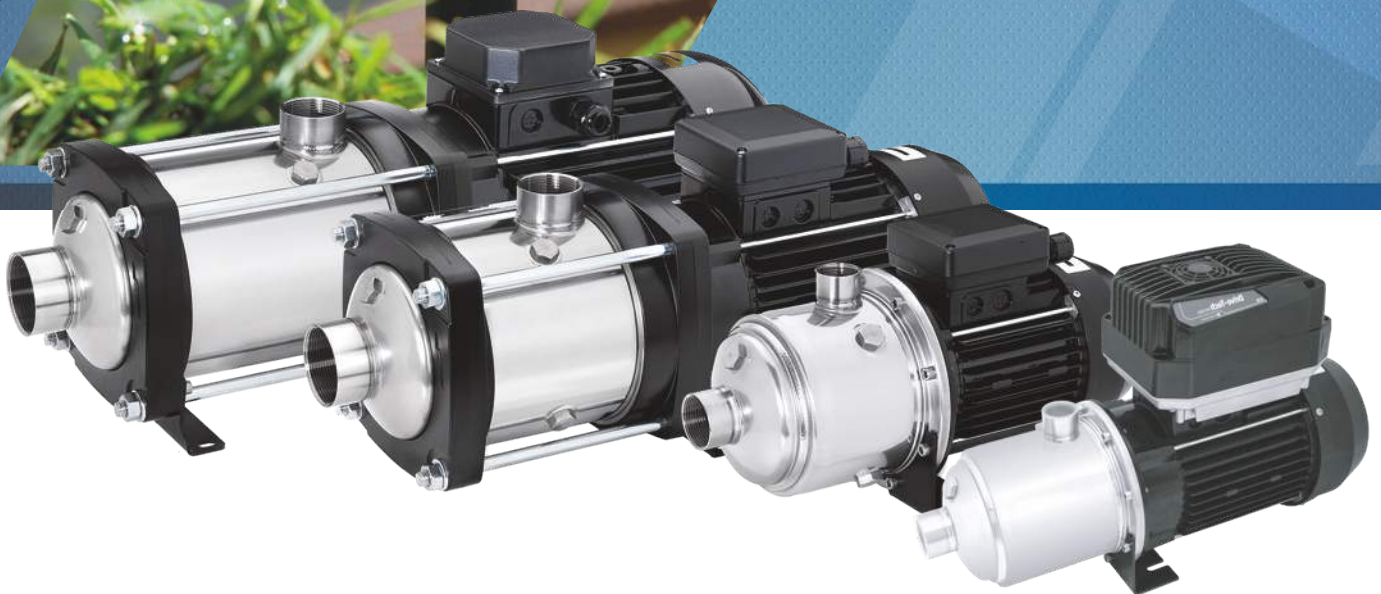

HORIZONTAL MULTISTAGE PUMPS 50 HZ

EH 9/6



STAINLESS STEEL HORIZONTAL MULTISTAGE PUMPS

FEATURES AND BENEFITS

APPLICATIONS



Water Distribution
Pressure Boosting



Circulation of hot+cold water
for heating, cooling,
conditioning systems



Irrigation
Gardening, Sprinklers



Wash down unit



Domestic, industrial and
agricultural systems

COMPACT CLOSE-COUPLED DESIGN

- Reinforced with tie rods and corrosion resistance (EH 15-20)
- Materials WRAS and ACS certificated
- Flexible application base plate (only for EH and EH DTm)
- Floating neck ring in PPS
- Heavy duty oversize motor shaft
- Impellers and diffusers are made of stainless steel
- Easy maintenance
- Connections: Rp threaded for inlet and outlet (NPT optional)
- Mechanical seal Type E0 = Carbon graphite / Ceramic alumina / EPDM: EH 3-5-9, EHsp 3-5; EH DTm 3-5-9
- Mechanical seal Type E1 = Carbon graphite / Silicon carbide / EPDM: EH 15-20

SUPERIOR EFFICIENCY AND PERFORMANCE

- Flow: up to 29 m³/h
- Head: up to 104 m
- Maximum working pressure 10 Bar
- Max. altitude at nominal load: 1000 m
- Maximum allowable amount of sand: 50 g/m³ (EH)
- Maximum ambient temperature: 40 °C
- The hydraulic characteristics are guaranteed, according to ISO standard 9906:2012, grade 3B

CONSTRUCTION OPTIONS

- Special mechanical seal (EH)
- Inlet and outlet connections NPT threaded

FAMILY CURVES

EH-Esp

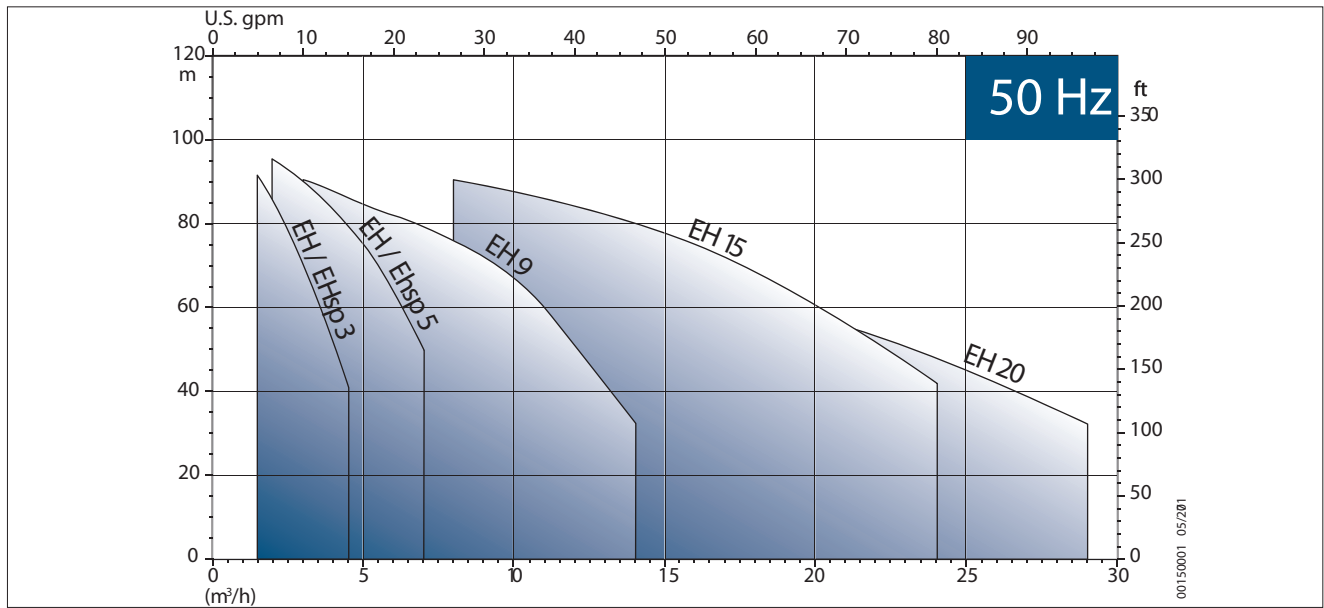

PUMP IDENTIFICATION CODE

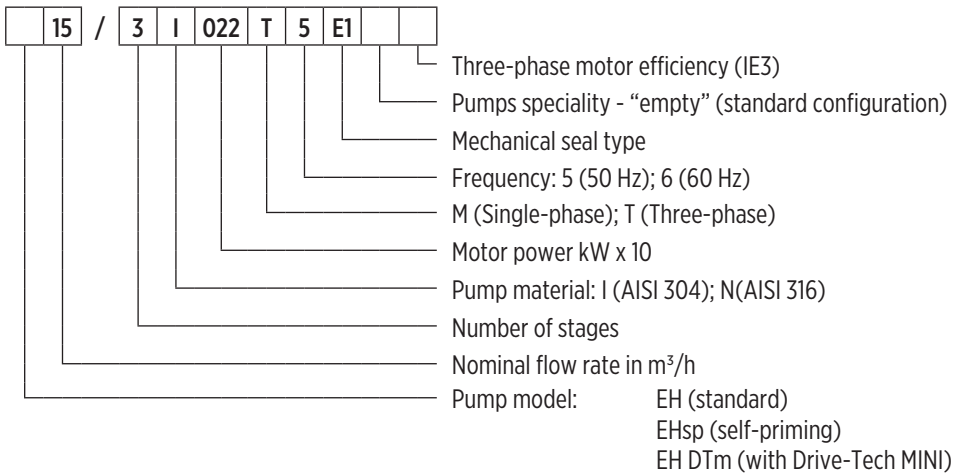

00140001EN 05/2021

GENERAL FEATURES

Model		3	5	9	15	20
Nominal flow [m ³ /h]		3.2	5.1	9.1	16.4	19
Maximum liquid temperature [°C]	Single-phase	55	55	55	55	55
	Three-phase (only industrial uses)	110	110	110	110	110
	Three-phase (domestic, commercial, other uses)	85	85	85	85	85
	Three-phase (drinking water)	85	85	85	85	85
	Version with Drive-tech _{MINI}	85	85	85	-	-
	Self-priming version	35	35	-	-	-
Max. D hydraulic [%]	Standard version	45.5	56.8	61	66.7	68.2
	Version with Drive-tech _{MINI}	42	56.8	61	-	-
	Self-priming version	40	53	-	-	-
Range [m ³ /h]	Standard version	1.5 - 4.5	2 - 7	3 - 14	8 - 24	10 - 28
	Version with Drive-tech _{MINI}	1.0 - 5.5	1.2 - 8.5	3 - 17	-	-
Pressione max. [bar]	Standard version	10	10	10	10	10
Material versions	I (AISI 304)	•	•	•	•	•
	N (AISI 316L)	•	•	•	•	•
Hydraulic connection (dimensions)	Rp (inlet - outlet) - standard	1"¼ - 1"	1"¼ - 1"	1"½ - 1"¼	2" - 1"½	2" - 1"½
	NPT (inlet - outlet) - optional	1"¼ - 1"	1"¼ - 1"	1"½ - 1"¼	2" - 1"½	2" - 1"½

"-" = not available
 • = available



MECHANICAL SEAL SPECIFICATIONS

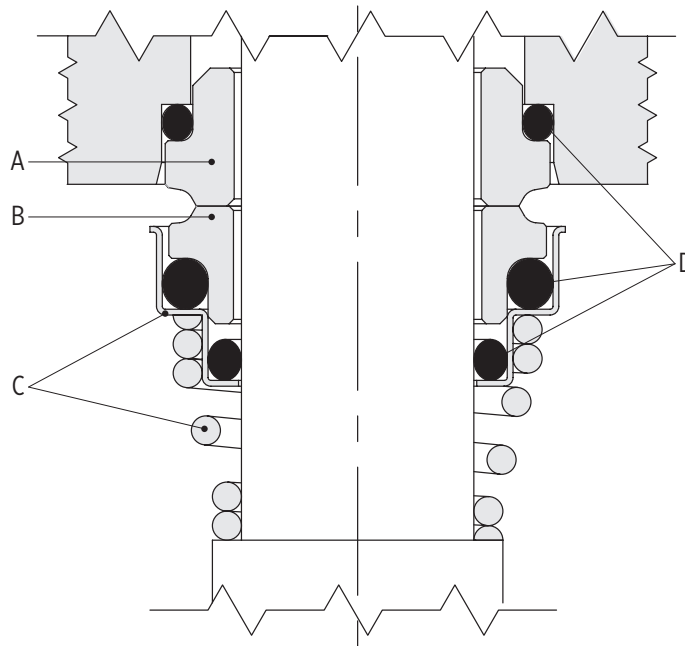

00130012_05/2017

STANDARD VERSION

Model	Type				Position				Temperature [°C]
					A Stationary part	B Rotating part	C Other components	D Elastomers	
EH 3-5-9 / EHsp 3-5 / EH DTm 3-5-9									
E0	V	B	G	E	Ceramic alumina	Carbon graphite	AISI 316	EPDM	-15 / +110
EH 15-20									
E1	B	Q	G	E	Carbon graphite	Silicon Carbide	AISI 316	EPDM	-15 / +110

AVAILABLE ON REQUEST (ONLY FOR EH)

Model	Type				Position				Temperature [°C]
					A Stationary part	B Rotating part	C Other components	D Elastomers	
E2	Q	Q	G	E	Silicon Carbide	Silicon Carbide	AISI 316	EPDM	-15 / +110
V3*	Q	Q	G	V	Silicon Carbide	Silicon Carbide	AISI 316	FKM	-10 / +110
V8*	Q	U	G	V	Silicon Carbide	Tungsten Carbide	AISI 316	FKM	-10 / +110

* on request version with stopper pin

Type	Material
B	Carbon graphite
E	EPDM
G	AISI 316
Q	Silicon Carbide
V	FKM
V	Ceramic alumina
U	Tungsten Carbide

MOTOR SPECIFICATIONS 50 HZ - EH-EHsp

- Asynchronous, TEFC (Totally Enclosed, Fan-Cooled)
- 2 pole
- Protection degree: IP55
- Insulation class: F
- Frequency of starts:
 - Max. 60 starts/hour for motor power up to 3 kW (with min. 1 minute resting time)
 - Max. 30 starts/hour for motor power from 4 kW (with min. 2 minute resting time)

SINGLE-PHASE VERSION

- Standard voltage 220-240 V ± 5%
- Thermal protection built into the motor

P _N [kW]	MOTOR SIZE	INPUT CURRENT I _N [A]	Capacitor		230 V - 50 Hz						
			μF	V	η _N [min ⁻¹]	I _s /I _N	η %	cos φ	T _N [Nm]	T _s /T _N	T _M /T _N
0.33	71	2.5	16	450	2920	6.5	64.8	0.88	1.08	1	1.6
0.45	71	3	16	450	2890	5.4	69.7	0.92	1.5	0.72	1.6
0.55	71	3.5	16	450	2860	4.6	72.6	0.94	1.83	0.59	1.85
0.75	71	4.67	16	450	2790	3.5	72.2	0.97	2.56	0.42	1.87
0.9	71	5.45	30	450	2875	4.8	75.3	0.93	3	0.47	1.67
1.1	71	6.6	30	450	2820	3.9	77	0.96	3.7	0.38	1.86
1.3	80	7.46	30	450	2860	4.2	80.8	0.94	4.35	0.57	1.86
1.5	80	8.56	30	450	2830	3.6	79.9	0.95	5.05	0.5	1.92
1.85	90	10.9	60	450	2760	2.8	76.6	0.96	6.4	0.39	2.4
2.2	90	12.6	60	450	2870	2.2	76.7	0.99	7.3	0.51	1.99

THREE-PHASE VERSION

- Efficiency class: IE3 (Premium Efficiency) according to IEC 60034-30-1:2014
- Electrical performance according to IEC 60034-2-1:2007
- Standard voltage:
 - 220-240 / 380-415 V ± 5 % up to 3 kW
 - 380-415 / 660-690 V ± 5 % from 4 kW
- Thermal protection to be provided into the starter panel by the installer

P _N [kW]	Rendimento / Efficiency η _N %						IE
	Δ 230 V Y 400 V			Δ 400 V Y 690 V			
	4/4	3/4	2/4	4/4	3/4	2/4	
0.75	80.9	81.5	79.6	-	-	-	3
1.1	82.7	84.6	84.2	-	-	-	
1.5	84.3	85.7	85.3	-	-	-	
2.2	86.1	86.7	85.4	-	-	-	
3	87.1	87.5	86.1	-	-	-	
4	-	-	-	88.1	88.7	87.7	
5.5	-	-	-	89.2	89.4	88.1	

P_N [kW]	MOTOR SIZE	N. of poles	f_N [Hz]	400 V - 50 Hz				
				$\cos \varphi$	I_s / I_N	T_N [Nm]	T_s / T_N	T_M / T_N
0.75	71	2	50	0.83	6.8	2.6	3.6	3.7
1.1	71			0.82	5.9	3.7	3.2	3.1
1.5	80			0.79	6.8	5.1	3.2	3.2
2.2	90			0.8	9.6	7.3	4.3	4.4
3	90			0.83	9.6	9.9	4.7	4.9
4	100			0.85	8.1	13.2	2.8	3
5.5	112			0.81	8.4	18.1	4.3	4.5

P_N [kW]	VOLTAGE U_N				n_N [min ⁻¹]	Motor operating conditions		
	Δ 230 V	Y 400 V	Δ 400 V	Y 690 V		Altitude Above Sea Level [m]	T. amb min/max [°C]	ATEX
	I_N [A]							
0.75	2.8	1.6	-	-	2800	≤ 1000	-15 / +40	No
1.1	4.1	2.3	-	-	2840			
1.5	5.7	3.3	-	-	2830			
2.2	8	4.6	-	-	2880			
3	10.4	6	-	-	2900			
4	-	-	7.7	4.4	2900			
5.5	-	-	11	6.4	2900			

MOTOR SPARE PARTS

SPARE PARTS LIST

Ref. No.	Part description
20.03	Motor bracket
20.06	Kit bearings
60.01	Motor housing and stator
60.02	Bearing housing
60.03	Fan
60.04	Fan cover and screws
60.05	Motor tie rods
60.06	Kit motor spare components
60.07	Motor housing foot
60.08	Terminal box cover and base
60.09	Terminal board

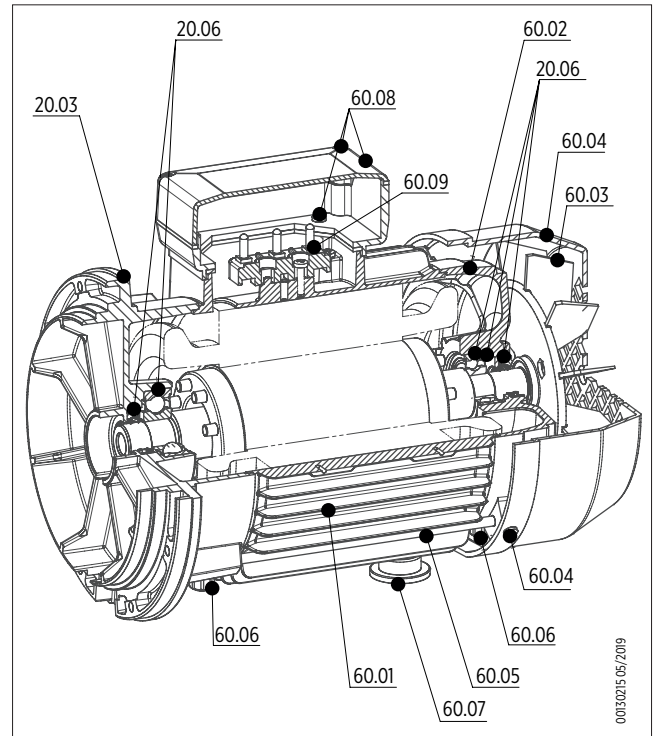

SPARE PARTS AND MATERIALS

EH 3-5-9

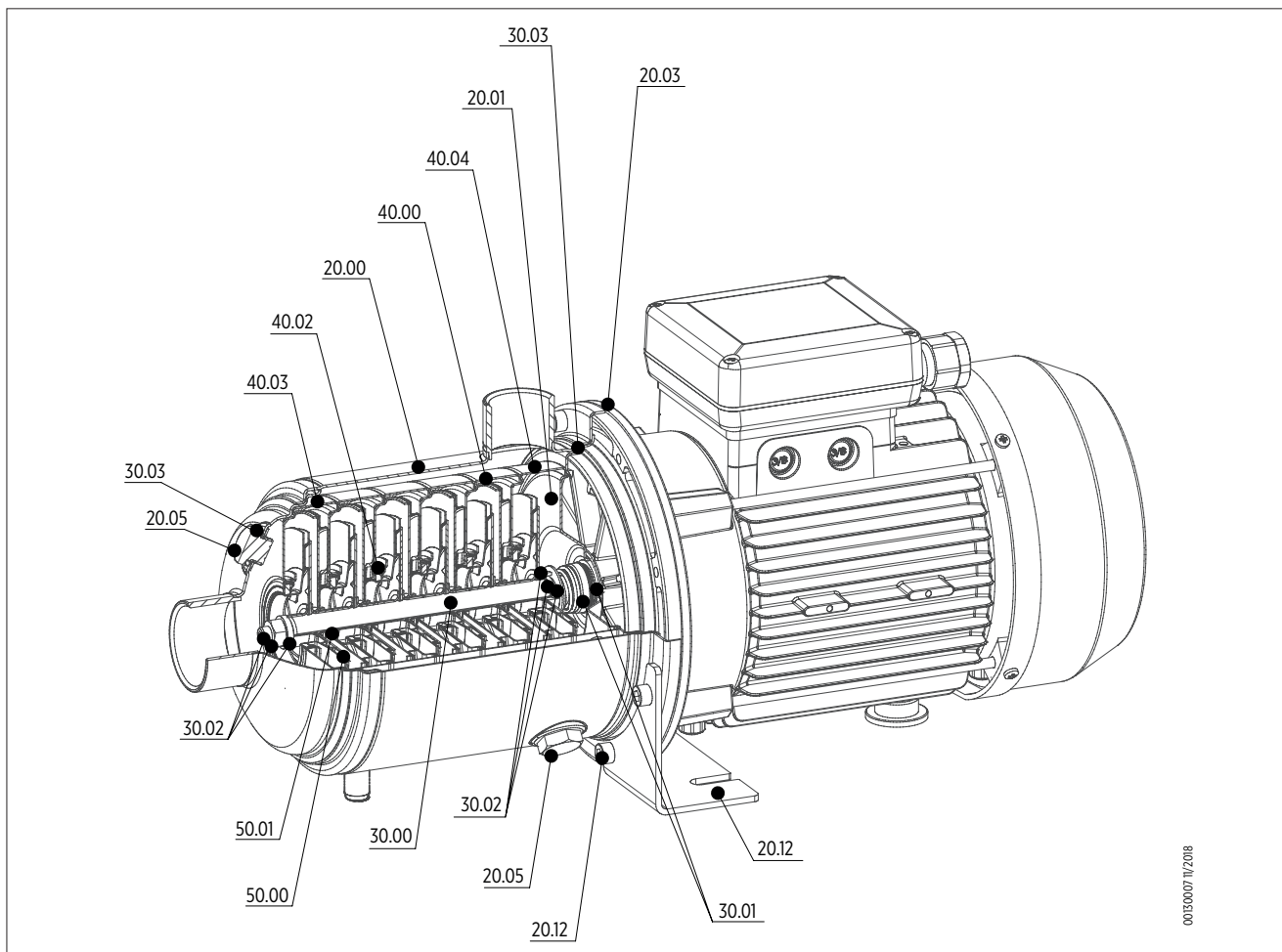

00500071/2018

PARTS IN CONTACT WITH LIQUID

Ref. No.	Part description	Material	Standard			
			I version		N version	
			ASTM/AISI	DIN/EN	ASTM/AISI	DIN/EN
20.00	Outer case	Stainless steel	AISI 304	14.301	AISI 316 L	14.404
20.01	Mechanical seal housing	Stainless steel	AISI 304	14.301	AISI 316 L	14.404
20.05	Filling plug	Stainless steel	AISI 304	14.301	AISI 316	14.401
30.00	Pump shaft	Stainless steel	AISI 304	14.301	AISI 316	14.401
30.01	Kit mechanical seal	Carbon graphite / Ceramic alumina / EPDM				
30.02	Mechanical seal fastening kit	Stainless steel	AISI 304	14.301	AISI 316	14.401
30.03	Kit O-rings	EPDM				
40.00	Stage housing and diffuser	Stainless steel	AISI 304	14.301	AISI 316 L	14.404
40.02	Floating neck ring	Stainless steel and PPS	AISI 304	14.301	AISI 316 L	14.404
40.03	Initial stage housing	Stainless steel	AISI 304	14.301	AISI 316 L	14.404
40.04	Last Stage with diffuser	Stainless steel	AISI 304	14.301	AISI 316 L	14.404
50.00	Impeller	Stainless steel	AISI 304	14.301	AISI 316 L	14.404
50.01	Impeller spacers	Stainless steel	AISI 304	14.301	AISI 316 L	14.404



SPARE PARTS LIST

Ref. No.	Part description
20.00	Outer case
20.01	Mechanical seal housing
20.03	Motor bracket
20.05	Filling plug
20.12	Support foot and screws
30.00	Pump shaft
30.01	Kit mechanical seal
30.02	Mechanical seal fastening kit

Ref. No.	Part description
30.03	Kit O-rings
40.00	Stage housing and diffuser
40.02	Floating neck ring
40.03	Initial stage housing
40.04	Last Stage with diffuser
50.00	Impeller
50.01	Impeller spacer

TECHNICAL DATA AND PERFORMANCE CURVES AT 50 HZ

HYDRAULIC PERFORMANCE AT 50 HZ

Pump model	Q = DELIVERY																
	l/min 0	16.7	25.0	33.3	50.0	75.0	100.0	116.7	133.3	166.7	200.0	233.3	283.3	333.3	400.0	466.7	533.3
	m ³ /h 0	1	1.5	2.0	3.0	4.5	6.0	7.0	8.0	10.0	12.0	14.0	17.0	20.0	24.0	28.0	32
	gpm 0	4.4	6.6	8.8	13.2	19.8	26.4	30.8	35.2	44.0	52.8	61.6	74.7	87.9	105.5	123.1	140.9
H = TOTAL METERS HEAD OF WATER COLUMN [m]																	
EH 3/2	22.4		20.0	18.7	15.5	9.7											
EH 3/3	33.2		29.3	27.4	22.5	13.8											
EH 3/4	43.7		38.3	35.6	29.1	17.5											
EH 3/5	54.0		46.8	43.4	35.2	20.7											
EH 3/6	65.1		56.7	52.6	42.8	25.4											
EH 3/7	75.3		65.1	60.2	48.7	28.4											
EH 3/8	87.6		77.0	71.7	58.8	35.6											
EH 3/9	98.0		85.8	79.8	65.2	39.1											
EH 5/2	23.5			21.7	20.5	18.3	15.0	11.8									
EH 5/3	34.8			31.9	30.0	26.5	21.3	16.5									
EH 5/4	46.2			42.4	39.9	35.2	28.4	21.9									
EH 5/5	57.3			52.1	48.8	42.7	34.0	25.8									
EH 5/6	69.5			64.0	60.3	53.4	43.2	33.6									
EH 5/7	80.7			73.9	69.5	61.3	49.2	37.9									
EH 5/8	93.9			87.1	82.6	73.8	60.6	47.9									
EH 5/9	105.4			97.5	92.3	82.4	67.4	53.0									
EH 9/2	23.7				22.0	20.8	19.7	18.9	18.1	15.6	11.9	6.9					
EH 9/3	35.3				32.7	30.8	29.1	27.9	26.6	22.8	17.2	9.7					
EH 9/4	47.4				44.2	41.9	39.7	38.2	36.5	31.7	24.3	14.4					
EH 9/5	60.1				56.6	54.0	51.4	49.7	47.8	42.1	33.0	20.7					
EH 9/6	71.8				67.4	64.2	61.0	58.9	56.5	49.5	38.5	23.7					
EH 9/7	84.3				79.4	75.8	72.2	69.9	67.1	59.2	46.5	29.3					
EH 9/8	96.0				90.3	86.1	81.9	79.2	76.0	66.8	52.2	32.5					
EH 15/2	28.5								25.0	24.0	22.9	21.7	19.2	15.9	10.3		
EH 15/3	43.3								38.3	36.9	35.3	33.5	29.9	25.0	16.5		
EH 15/4	57.9								51.4	49.5	47.4	45.0	40.3	33.8	22.5		
EH 15/5	72.6								64.5	62.2	59.6	56.7	50.8	42.7	28.6		
EH 15/6	87.5								78.2	75.5	72.5	69.0	62.1	52.5	35.6		
EH 15/7	101.9								90.8	87.5	84.0	79.8	71.7	60.5	40.7		
EH 20/2	31.2									27.9	27.2	26.5	25.3	23.1	18.5	12.7	
EH 20/3	46.8									41.9	40.8	39.8	37.8	34.6	27.7	19.0	
EH 20/4	62.5									56.0	54.6	53.2	50.6	46.3	37.2	25.6	
EH 20/5	78.5									70.6	68.9	67.3	64.1	58.9	47.6	33.2	

EH 9 - TECHNICAL DATA

1 ~ ELECTRIC PUMP TECHNICAL DATA

Pump model	MOTOR SIZE	MOTOR NOMINAL POWER		INPUT POWER [kW]	Capacitor 450 V [µf]	INPUT CURRENT [A] 220-240 V	Dimensions [mm]							Weight [Kg]
		[kW]	[HP]				A	F	ØB	H	L1	L2	L3	
EH 9/2	71	0.75	1	0.91	16	4.3	118	380	144	207	74	101	-	11.6
EH 9/3	71	1.1	1.5	1.35	30	6.3	118	380	144	207	74	101	-	13.2
EH 9/4	80	1.5	2	1.74	30	8.2	148	452	162	214	74	128	-	17
EH 9/5	90	2.2	3	2.51	60	11.1	178	527	179	221	74	172	-	23
EH 9/6	90	2.2	3	2.89	60	12.7	208	557	179	221	74	172	192	23.8

3 ~ ELECTRIC PUMP TECHNICAL DATA

Pump model	MOTOR SIZE	MOTOR NOMINAL POWER		INPUT POWER [kW]	INPUT CURRENT [A]		Dimensions [mm]							Weight [Kg]
		[kW]	[HP]		220-240 V	380-415 V	A	F	ØB	H	L1	L2	L3	
EH 9/2T	71	0.75	1	0.87	2.7	1.6	118	382	144	207	74	101	-	11.2
EH 9/3T	71	1.1	1.5	1.24	3.8	2.2	118	382	144	207	74	101	-	12
EH 9/4T	80	1.5	2	1.70	5.5	3.2	148	449	162	214	74	128	-	15.8
EH 9/5T	90	2.2	3	2.20	7.1	4.1	178	526	179	221	74	172	-	21.8
EH 9/6T	90	2.2	3	2.61	8.2	4.7	208	556	179	221	74	172	192	22.4
EH 9/7T	90	3	4	3.08	9.5	5.5	238	621	179	221	74	172	222	26
EH 9/8T	90	3	4	3.49	10.4	6.0	268	651	179	221	74	172	252	26.6

DIMENSIONAL DRAWINGS

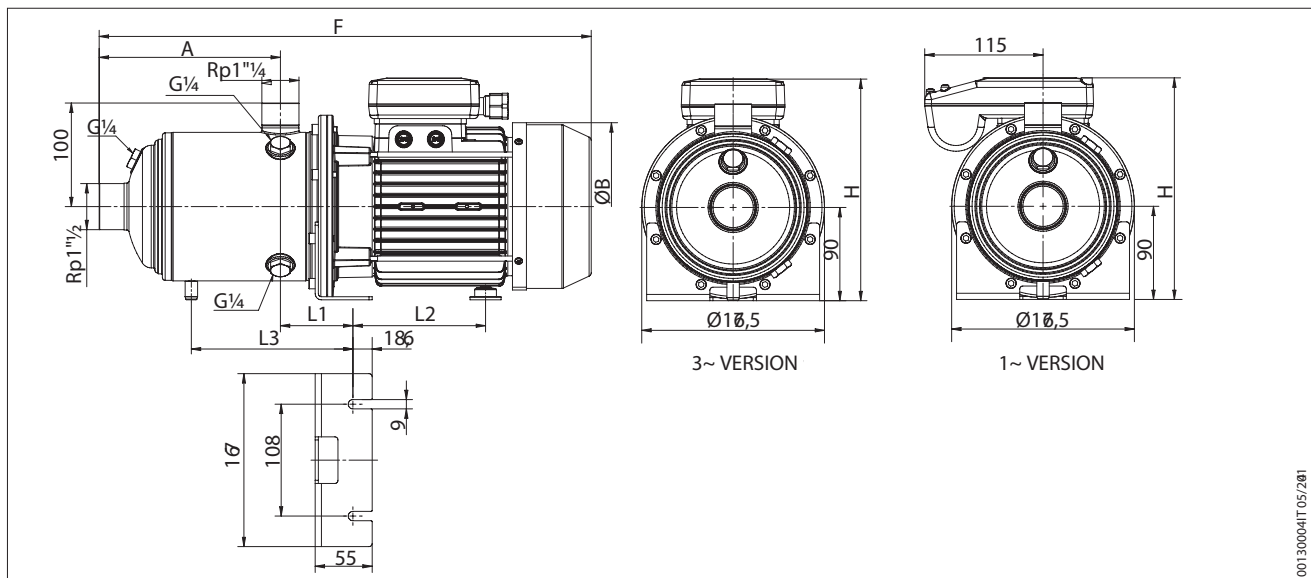

00130004IT05/201

EH 9 - PERFORMANCE CURVES AT 50 HZ

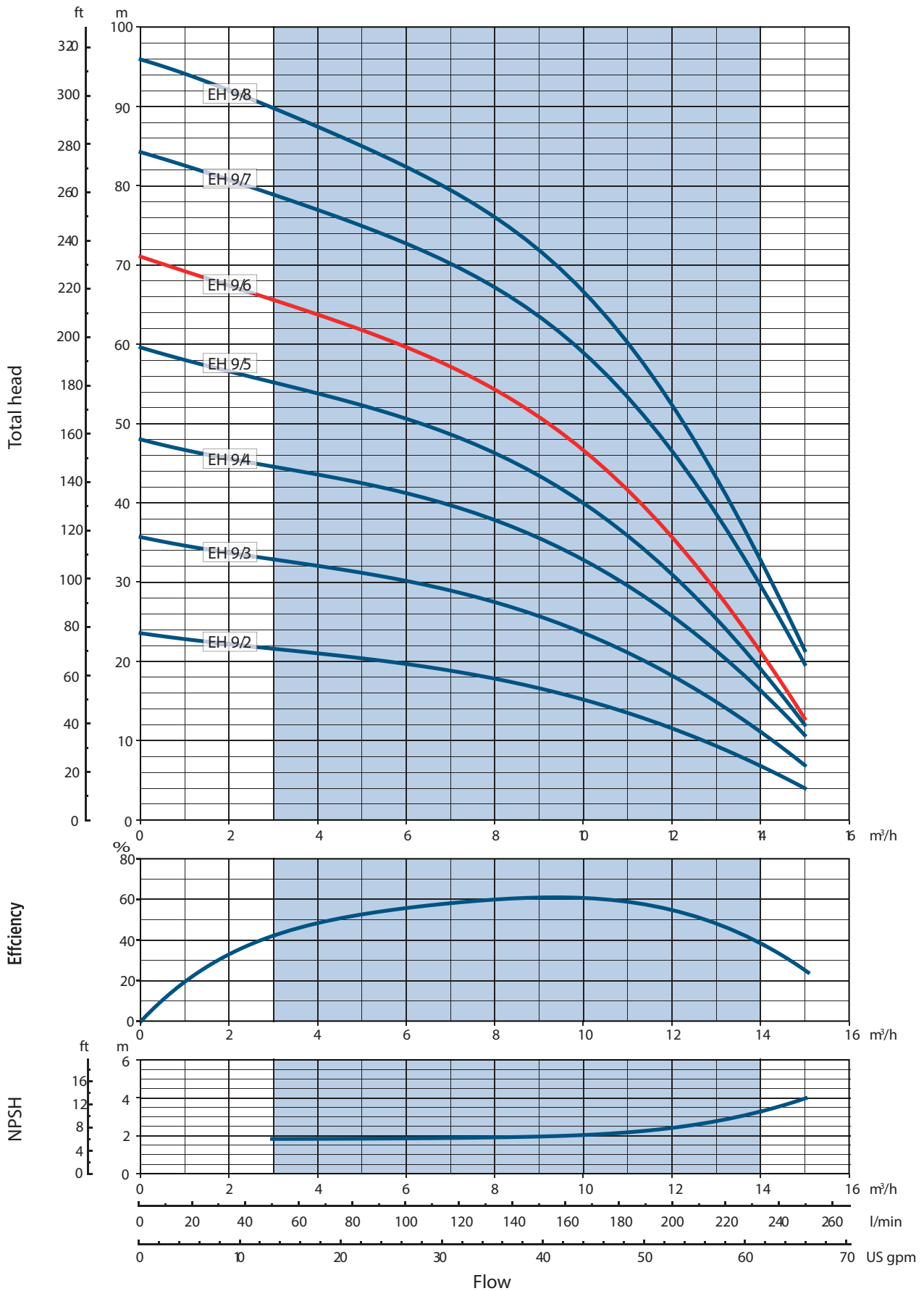



Franklin Electric

Franklin Electric Europa GmbH
Rudolph-Diesel-Str. 20 - 54516 Wittlich
GERMANY

Phone: +49 (0) 6571 - 105-0
Fax: +49 (0) 6571 - 105-510
Email: info@franklin-electric.de

Franklin Electric S.r.l.
Via Asolo, 7 - 36031 Dueville (Vicenza)
ITALY

Phone: +39 0444 361114
Fax: +39 0444 365247
Email: sales.it@fele.com



10000008724 EN REV.00_07-2021



franklinwater.eu

Single member - Company subject to the control and coordination of Franklin Electric Co., Inc.
Franklin Electric reserves the right to amend specification without prior notice.