

ENM 25S - ENM electric pumps



The ENM series are professional versions of self-priming electric transfer pumps in brass. Equipped with an oversized single-phase asynchronous motor and long-lasting rotary switch, they are designed for heavy applications.

These pumps are equipped with a strong suction capacity, they can work even with discontinuous presence of the liquid and the flow is reversible. They are really multifunctional pumps, capable of solving multiple pumping problems. For each application, it is necessary to check the suitability and choose appropriate gaskets.

The product are particularly suitable for use:

- agriculture (fungicides, liquid fertilizers, components on agricultural machinery, irrigation)
- professional use (continuous over time and heavy-duty applications, installation on systems)
- industry (installation on plant, machinery, machinery, production lines)

Hydraulic specifications

- Maximum capacity : 88 lt/min
- Maximum head : 46 m
- Gasket on the shaft: Seal
- Maximum priming height : 6 m
- Threaded ports: 1"
- Maximum liquid density 1.1g/cm³ free of hard particles in suspension
- Maximum temperature 90°C
- Not suitable for aggressive liquids towards pump construction materials and gaskets (see technical specifications)
- Not appropriate for the transfer of petrol, solvents and, in general, in environments with risk of explosion and fire
- Possibility of reversing the pumping flow
- Coupling with impeller free
- Complete with a pair of brass hose fittings for pipes 25 (one straight and one curved)
- Possibility of working for short periods with closed pipes
- During installation, the pump must be filled with liquid, subsequently this operation is no longer necessary

Technical specifications

Material

- Pump Parts: Brass
- Shaft : AISI 316
- Impeller : Brass
- Gaskets: NBR

MOTOR

- Powered with a Single-phase asynchronous 230V 50Hz
- Equipped with MEC 80 motor (2800 rpm 2.0HP / 1,5 KW)
- Service S1
- Ip protection degree 44
- Insulation class F
- Power connection via cable end Cable with Schuko plug 2m
- Switching on and reversing of the pumping flow through inverter switch

Pump features				
Ports	Hose fitting	Priming ability	Qmax	Hmax
1"	25 mm	6 m	88 lt/min	46 m

Overall dimensions				
W	L	H	Weight	Leq A*
350 mm	158 mm	230 mm	13.2 kg	83 dB

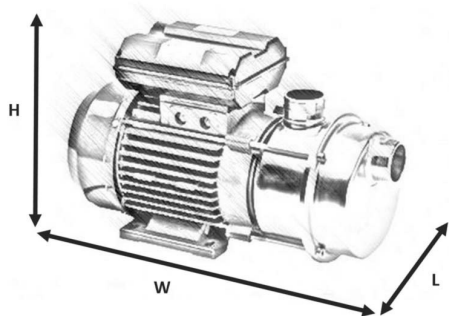

Capacity (l/min)				
1m	5m	10m	20m	30m
88 lt/min	83 lt/min	77 lt/min	60 lt/min	43 lt/min

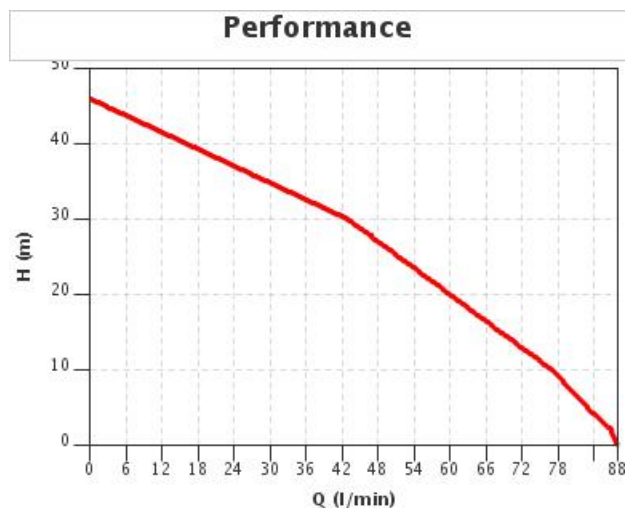

Characteristics referring to operation with water at 20 °
 * Leq A detected 1 meter from the pump surface

Available for the hydraulic part on request

Available for the motor on request

- [By-pass 25](#)

FOR USE AND TRANSPORT

- Feet for ceiling fixing
- Feet for fixing to: wall
- [Handle](#)
- [Plate with handle](#)
- [Trolley](#)

Liquids loading / unloading

- [Filler plug \(brass\)](#)
- [Drain tap \(brass\)](#)

SEALS

- [Mechanical seal](#)
- Viton

Motor

- Advanced inverter
- Special supply voltages
- [Terminal board](#)

Plug on request

- [American plug](#)
- [Australian plug](#)
- [Stripped cable](#)

We reserve the right to make changes without prior notice.

TELLARINI POMPE di G. Tellarini & C.

Via E. Maiorana, 4 - 48022 Lugo (Ravenna) Italy - Tel. +39 0545 22508 - Fax +39 0545 32362
<https://www.tellarini.com> - Email: tellarini@tellarini.com - sales@tellarini.com

ENT 25S - ENT electric pumps



ENT series are professional versions of self-priming brass transfer pumps. Equipped with an oversized three-phase asynchronous motor and long life rotary switch, they are designed for heavy duty applications.

These pumps are equipped with a strong suction capacity, can operate even with discontinuous presence of the liquid and you can reverse the flow. They are really multifunction pumps, able to solve multiple pumping problems. For each application it is necessary to verify the suitability and choose the appropriate gaskets.

The product are particularly suitable for use:

- agriculture (fungicides, liquid fertilizers, components on agricultural machinery, irrigation)
- professional use (continuous over time and heavy-duty applications, installation on systems)
- industry (installation on plant, machinery, machinery, production lines)

Hydraulic specifications

- Maximum capacity : 88 lt/min
- Maximum head : 46 m
- Gasket on the shaft: Seal
- Maximum priming height : 6 m
- Threaded ports: 1"
- Maximum liquid density 1.1g/cm³ free of hard particles in suspension
- Maximum temperature 90°C
- Not suitable for aggressive liquids towards pump construction materials and gaskets (see technical specifications)
- Not appropriate for the transfer of petrol, solvents and, in general, in environments with risk of explosion and fire
- Possibility of reversing the pumping flow
- Coupling with impeller free
- Complete with a pair of brass hose fittings for pipes 25 (one straight and one curved)
- Possibility of working for short periods with closed pipes
- During installation, the pump must be filled with liquid, subsequently this operation is no longer necessary

Technical specifications

Material

- Pump Parts: Brass
- Shaft : AISI 316
- Impeller : Brass
- Gaskets: NBR

MOTOR

- Powered with a Three-phase asynchronous 400V 50Hz
- Equipped with MEC 80 motor (2800 rpm 2.0HP / 1,5 KW)
- Service S3-80%
- Ip protection degree 44
- Insulation class F
- Power connection via cable end Stripped cable 2m
- Switching on and reversing of the pumping flow through inverter switch

Pump features				
Ports	Hose fitting	Priming ability	Qmax	Hmax
1"	25 mm	6 m	88 lt/min	46 m

Overall dimensions				
W	L	H	Weight	Leq A*
350 mm	158 mm	230 mm	13.2 kg	83 dB

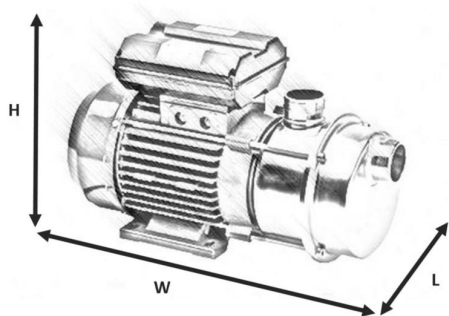

Capacity (l/min)				
1m	5m	10m	20m	30m
88 lt/min	83 lt/min	77 lt/min	60 lt/min	43 lt/min

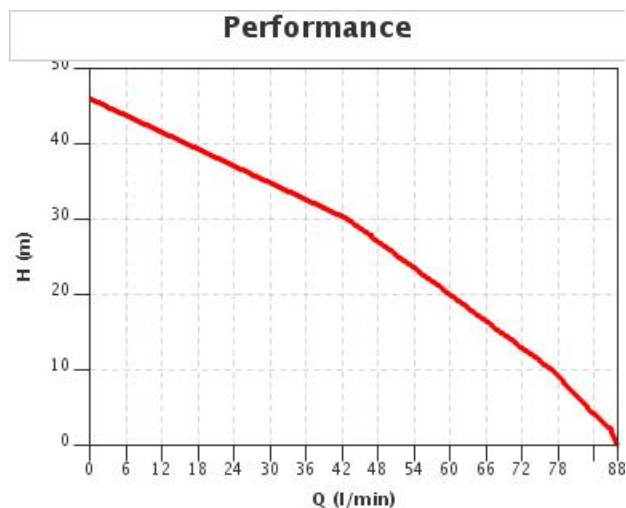

Characteristics referring to operation with water at 20 °
 * Leq A detected 1 meter from the pump surface

Available for the hydraulic part on request

Available for the motor on request

- [By-pass 25](#)

FOR USE AND TRANSPORT

- Feet for ceiling fixing
- Feet for fixing to: wall
- [Handle](#)
- [Plate with handle](#)
- [Trolley](#)

Liquids loading / unloading

- [Filler plug \(brass\)](#)
- [Drain tap \(brass\)](#)

SEALS

- [Mechanical seal](#)
- Viton

Motor

- [Terminal board](#)

We reserve the right to make changes without prior notice.

TELLARINI POMPE di G. Tellarini & C.

Via E. Maiorana, 4 - 48022 Lugo (Ravenna) Italy - Tel. +39 0545 22508 - Fax +39 0545 32362
<https://www.tellarini.com> - Email: tellarini@tellarini.com - sales@tellarini.com