

APPLICAZIONI

Elettropompe autoadescenti Jet garantiscono un'ottima resa idraulica e una notevole capacità di portata. Possono aspirare fino a 8 mt. di profondità e sono in grado di funzionare perfettamente anche in presenza di acque miscelate a gas. Adatte per il sollevamento e la distribuzione negli impianti di depurazione delle piscine.

APPLICATION

Selfpriming jet water pumps with a very high hydraulic performance and a considerable capacity. Able to pump up to 8 mt. depth and work perfectly even in soda-water. Suitable for water lifting and distribution in purification systems for swimming pools.



GIRANTE - IMPELLER

LIMITI D'IMPIEGO

- Temperatura liquido fino a 35°C (per un uso domestico secondo EN 60335-2-41)
Temperatura max. liquido: 35°C (per altri impieghi)
- Temperatura ambiente fino a 40°C
- Servizio continuo

MOTORE

- Monofase 230V-50Hz
- Trifase 230/400V-50Hz
- Motore elettrico ad induzione a 2 poli ($n = 2850 \text{ min}^{-1}$)
- Isolamento Classe F
- Protezione IPX 5

MATERIALI

- | | |
|---------------------|---------------------|
| - Corpo pompa | Polipropilene |
| - Supporto motore | Alluminio |
| - Girante | Noryl |
| - Filtro cestello | Polipropilene |
| - Tenute meccaniche | Silicio/Silicio/NBR |

OPERATING CONDITIONS

- Liquid temperature up to 35°C (for home use according to EN 60335-2-41)
Temperature max. liquid: 35°C (for other uses)
- Ambient temperature up to 40°C
- Continuous duty

MOTOR

- Single-phase 230V-50Hz
- Three-phase 230/400V-50Hz
- Two-Pole induction motor ($n = 2850 \text{ min}^{-1}$)
- Insulation Class F
- Protection IPX 5

MATERIALS

- | | |
|-------------------|---------------------|
| - Pump body | Moplen |
| - Motor Support | Aluminium |
| - Impeller | Noryl |
| - Filter basket | Moplen |
| - Mechanical seal | Silicon/Silicon/NBR |

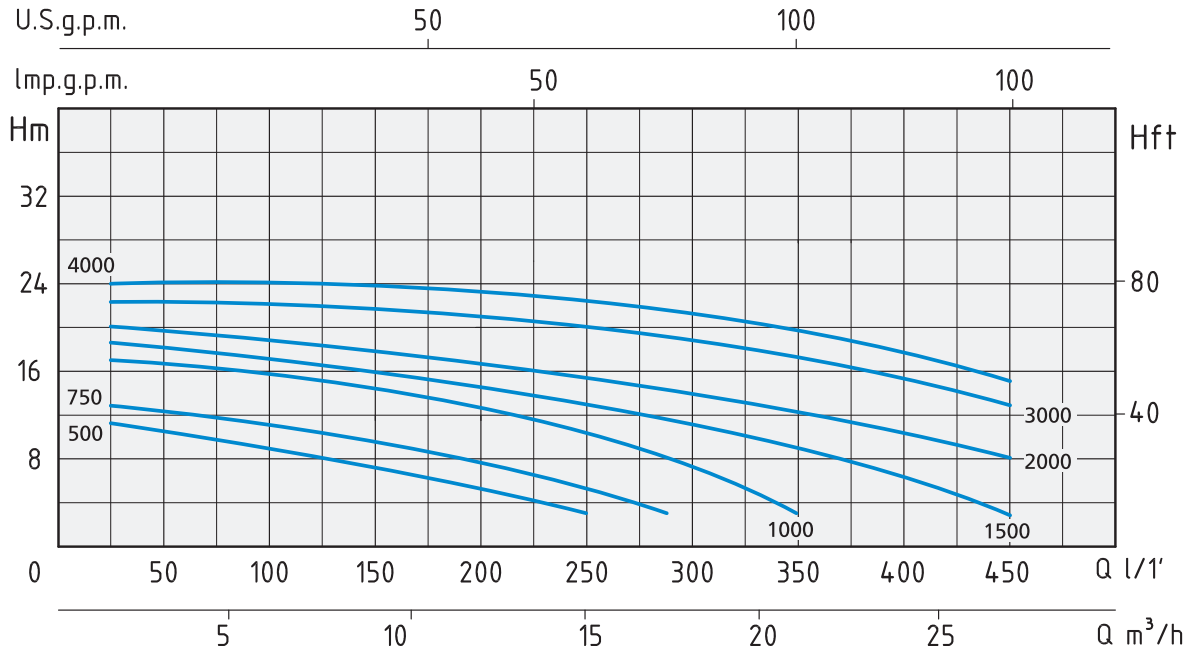

TIPO - TYPE		POTENZA NOMINALE NOMINAL POWER		POTENZA ASSORBITA INPUT POWER	AMPERE		Q = PORTATA - CAPACITY																	
Monofase Single-phase	Trifase Three-phase	P2		P1	Monofase Single-phase	Trifase Three-phase	Q = PORTATA - CAPACITY																	
		HP	KW	KW			m³/h	1,5	3	4,5	6	9	12	15	16,5	18	21	24	27					
							Prevalenza manometrica totale in m.C.A. - Total head in meters w.c.																	
							H (m)	11	10,5	10	9	7	5	2,5										
SWIMM 500		0,5	0,37	0,6	2,8			13	12,5	12	11,5	10	7,5	4,5	3									
SWIMM 750		0,75	0,55	0,75	3,5			17	16,5	16	15,5	14,5	13	10	8,5	7	3							
SWIMM 1000		1	0,75	1,15	5,1			18	17,5	17	16,5	15,5	14,5	13	12	11	9	6	3					
SWIMM 1500		1,5	1,1	1,4	6,2			20	19	18,5	18	17,8	17	15,7	14,8	14	12	10	8					
SWIMM 2000		2	1,5	1,43	6,3			22,4	22,2	22,1	22	21	20,5	20	19	18	17	15	13					
	SWIMM 3000T	3	2,2	2		3,7		24	23,5	23,3	23	22,8	22,5	22	21	20	19	17,5	15	13				
	SWIMM 4000T	4	3	2,4		4,3																		

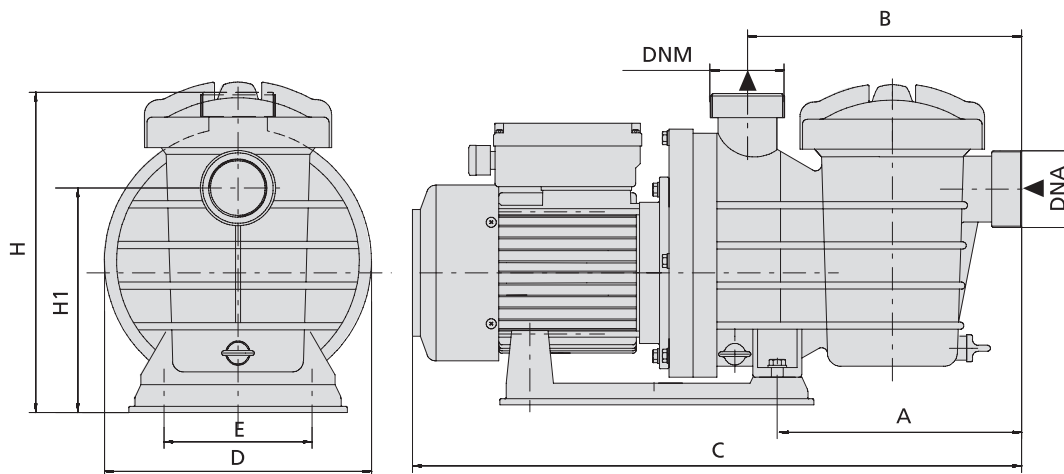

TIPO TYPE	DIMENSIONI mm - DIMENSIONS mm										DIMENSIONI DIMENSIONS mm			PESO WEIGHT Kg
	A	B	C	D	E	H	H1	DNA	DNM	P	L	H		
Monofase Single-phase														
SWIMM 500	77	215	465	160	122	234	153	1" 1/2	1" 1/2	180	510	255	8,7	
SWIMM 750	196	223	502	220	122	270	185	1" 1/2	1" 1/2	241	530	288	10,9	
SWIMM 1000	196	223	502	220	122	270	185	1" 1/2	1" 1/2	241	530	288	12,2	
SWIMM 1500	211	230	520	238	159	331	225	2"	2"	255	554	355	12,9	
SWIMM 2000	274	290	600	270	195	330	225	2"	2"	300	630	390	16,2	
	SWIMM 3000T	274	290	600	270	195	330	225	2"	2"	300	645	400	17,5
	SWIMM 4000T	274	290	645	270	195	330	225	2"	2"	300	670	400	18,5